

# LPH23 High-pressure Cage Guided Control Valve



Code	Actuator	Action	Air Fail Position	Control	Structure	Body Material	Sealing Material	Core Material	Connection	DN	PN
LPH23-	1 Pneumatic	S Single-acting	1 Normally Open	B Control	4 Low temperature type	A CF3M	P PTFE	A CF3M	1 Flange		
	2 Pneumatic & Handwheel	0 Others	2 Normally Closed	C Intelligent	5 Bellows type	B CF8M	Y FEP(F46)	B CF8M	5 Weld		
	4 Electric C220V		4 Held	0 Others	6 High temperature type	C CF8	R BODY	C CF8	0 Others		
	5 Electric AC380V		0 Others		7 Normal	D WCB	S Stellite	I CF3			
	0 Others				0 Others	1 CF3	3 Gr	L CE3MN			
						L CE3MN	4 WC	2 Ti			
						2 Ti	0 Others	0 Others			
						5 WCC					
						0 Others					



## Overview

LPH23 high-pressure cage guided control valve is designed for heavy duty, high temperature, high pressure services. The compact valve body, having a S-shape flow passage that features low pressure loss and a stabilizer that regulates turbulent flow around the cage, allows a large flow capacity, rangeability, and high accuracy flow characteristics. The valve plug is structured in a pressure-balanced type that permits flow control of a high differential pressure with a small actuating force. The actuator integrated with simplest mechanisms utilizes a compact yet powerful diaphragm actuator loaded with multiple springs.

LPH23 valves are widely applicable for reliable control of high temperature, high pressure process lines.

## Specifications

Nominal size	40,50,65,80,100,150,200mm 1 1/2, 2, 2 1/2, 3, 4, 6, 8 inch
Pressure rating	ANSI Class 900,1500,2500 JIS 63K
Connection	Flange:RF, RJ Flanged end:JIS B2201-1984, ANSI B16.5-1981 Weld:SW ( 40-80mm ) , BW ( 80-200mm )
Body material	WCB,304,316,304L,316L,CE3MN
Core material	304,316,304L,316L,CE3MN



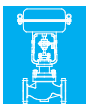

# LPH23

## High-pressure Cage Guided Control Valve



Bonnet	Plain bonnet ( -5~230°C ) Extension bonnet Type 1 ( 230~566°C)
Packing / Grease	Grease not provided: When V shaped PTFE packing or PTFE yarn packing is used. Grease provided: When graphite packing is used.
Gasket	Type: Flat type, serrated type Material: Carbon steel (S15C), stainless steel (SUS316, SUS316L, SUS329J1), copper, aluminum, titanium, ASTM B574 (Hastelloy C-276 equivalent), or Alloy 20
Flow characteristics	Equal percentage (%V), Linear (LV)
Actuator	Pneumatic, electric: refer to the attachment.
Performance	Inherent range ability 50 : 1 ANSI B16.104-1976 III , Leakage less than 0.1% of maximum valve capacity. Hysteresis error: With positioner: Within 1% F.S. Linearity: With positioner: Within $\pm 1\%$ F.S.

### Characteristics

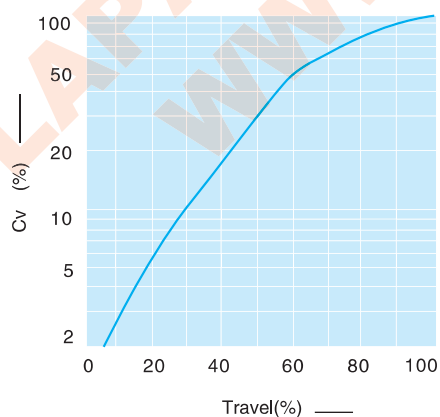

Equal percentage characteristics

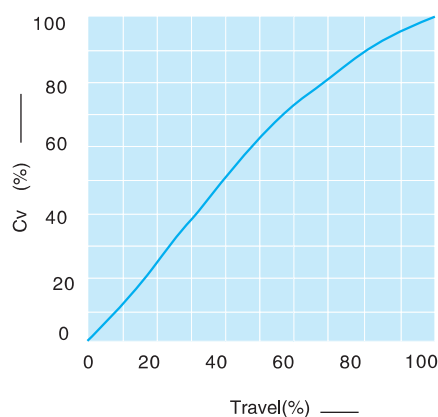

Linear characteristics



# LPH23 High-pressure Cage Guided Control Valve



## Exploded View

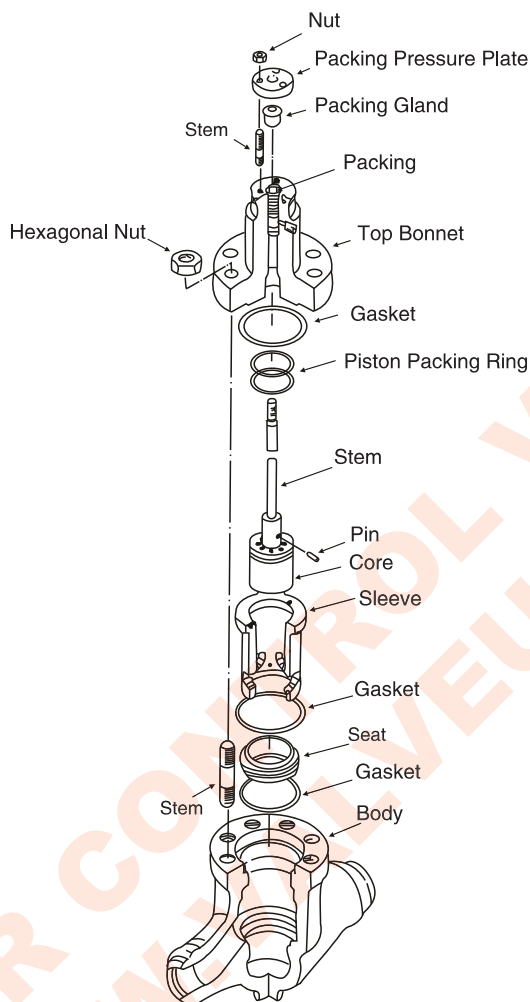

## Cv Value and Travel

mm

DN		40			50			80			100			150			200		
Diameter		25	32	40	32	40	50	50	65	80	65	80	100	100	125	150	125	150	200
Cv	%V	ANSI 900, 1500, JIS 63K																	
		ANSI 2500																	
	LV	ANSI 900, 1500, JIS 63K																	
		ANSI 2500																	
Rated Travel		25						38						50			75		

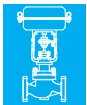

# LPH23 High-pressure Cage Guided Control Valve



## Allowable Differential Pressure

With ZHA or ZVA actuator

Air-to-close

100KPa

PN	Actuator	Supply pressure	Spring range	Allowable differential pressure					
				DN					
				40	50	80	100	150	200
ANSI 900 ANSI 1500 JIS 63K	ZHA3D	2.8	0.4 ~ 2.0	153	116	78	58	—	—
				264	190	113	74	—	—
		3.0		153	116	78	58	—	—
				264	248	152	103	—	—
		3.5		261	233	156	117	64	—
				264	264	172	118	64	—
	4.0	264	233	156	117	78	—		
	ZHA4D	2.8	0.4 ~ 2.0	211	201	135	101	67	50
				264	264	227	159	91	57
				263	201	135	101	67	50
				264	264	264	210	125	83
		3.5	0.8 ~ 2.4	—	264	264	202	135	95
				—	264	264	235	142	95
				—	—	—	202	135	101
				—	—	—	264	226	158
		4.0	0.8 ~ 2.4	—	—	—	202	135	101
				—	—	—	264	226	158
				—	—	—	138	92	69
—				—	—	234	226	158	
ZVA5D	2.8	0.4 ~ 2.0	—	—	—	138	92	69	
—	—	—	234	226	158	—	—		
ANSI2500	ZHA3D	2.8	0.4 ~ 2.0	153	116	106	71	44	—
				264	190	169	99	45	—
		3.0		153	116	106	71	44	—
				339	248	222	135	67	—
		3.5		261	233	212	142	78	—
				377	277	249	153	78	—
	4.0	306	233	212	142	88	—		
	44	423	381	142	134	—			
	ZHA4D	2.8	0.4 ~ 2.0	211	201	183	123	76	67
				440	359	324	203	110	91
				263	201	183	123	76	67
				440	440	415	265	148	125
		3.5	0.8 ~ 2.4	289	289	289	246	153	135
				440	440	440	195	167	142
				420	403	367	246	153	135
				440	440	440	440	263	226
		4.0	0.8 ~ 2.4	420	403	367	246	153	135
				440	440	440	440	263	226
				—	—	—	168	104	92
				—	—	—	294	166	141
	ZVA5D	2.8	0.4 ~ 2.0	—	—	—	168	104	92
	—	—	—	294	166	141	—	—	



# LPH23 High-pressure Cage Guided Control Valve



Air-to-open

100KPa

PN	Actuator	Supply pressure	Spring range	Allowable differential pressure					
				DN					
				40	50	80	100	150	200
ANSI 900 ANSI 1500	ZHA3R	2.8	0.8 ~ 2.4	153	116	78	58	-	-
				264	190	113	74		
		3.0		190	175	113	74	-	-
	264			190	113	74			
	3.5	-		189	-	-	-	-	
		-		190	-	-	-	-	
	ZHA4R	2.8	0.8 ~ 2.4	211	201	135	101	67	50
				264	264	227	159	91	57
		3.0		-	210	203	152	91	57
	-			264	227	159	91	57	
	3.5	-		-	210	159	-	-	
		-		-	227	159	-	-	
ZVA5R	2.8	0.8 ~ 2.4	-	-	-	138	52	69	
ZVA6R	4.0	1.9 ~ 3.5	-	-	-	264	-	-	
			-	-	-	264	-	-	
	5.0		1.9 ~ 4.0	-	-	-	-	191	-
-	-	-	-	-	-	264	-		
ANSI 2500	ZHA3R	2.8	0.8 ~ 2.4	153	116	106	71	44	-
				164	190	169	99	45	
		3.0		190	175	159	99	44	-
	264			190	169	99	45		
	3.5	-		189	169	-	-	-	
		-		190	169	-	-	-	
	ZHA4R	2.8	0.8 ~ 2.4	211	201	183	123	76	67
				440	359	324	203	110	91
		3.0		-	210	210	184	110	91
	-			359	324	203	110	91	
	3.5	-		-	-	203	-	-	
		-		-	-	203	-	-	
ZVA5R	2.8	0.8 ~ 2.4	-	-	-	168	104	92	
ZVA6R	4.0	1.9 ~ 3.5	-	-	-	362	-	-	
			-	-	-	440	-	-	
	5.0		1.9 ~ 4.0	-	-	-	-	216	-
-	-	-	-	-	-	368	-		

1. Column bordered with bold lines denote types provided with standard-type actuator
2. Take care not to cause the maximum allowable differential pressure to exceed the maximum operating pressure designated by ANSI B 16.34-1981.
3. Inlet pressure P1 is not allowed to exceed the maximum permissible differential pressure when the valve is closed.
4. The upper figures denote the operating allowable differential pressure. The lower denote allowable differential pressure at full closure.
5. The allowable differential pressure condition in the table is  $\Delta P = P1(P2 = 0)$  when it is closed, and the differential pressure changes slightly as outlet pressure P2.





# LPH23 High-pressure Cage Guided Control Valve



With ZVP actuator

100KPa

PN	Actuator	DN	Supply pressure		
			3	4	5
ANSI900、1500 JIS63K	ZVP5	150	198	264	264
			242	264	264
ANSI 2500			198	264	330
281			289	440	
ANSI900、1500 JIS63K	ZVP6	200	191	255	264
			264	264	264
ANSI 2500			192	255	319
440			440	440	

1. Column bordered with bold lines denote types provided with standard-type actuator
2. Take care not to cause the maximum allowable differential pressure to exceed the maximum operating pressure designated by ANSI B 16. 34-1981.
3. Inlet pressure P1 is not allowed to exceed the maximum permissible differential pressure when the valve is closed.
4. The upper figures denote the operating allowable differential pressure. The lower denote allowable differential pressure at full closure.
5. The allowable differential pressure condition in the table is  $\Delta P = P1(P2 = 0)$  when it is closed, and the differential pressure changes slightly as outlet pressure P2.

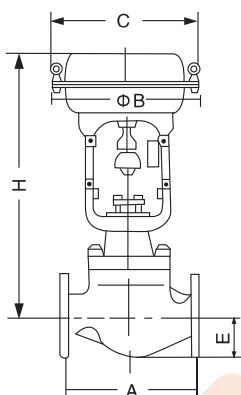

ZHA actuator

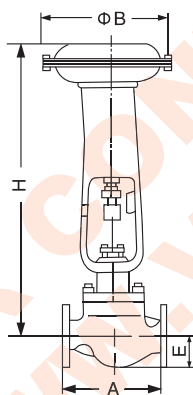

ZVA5 actuator

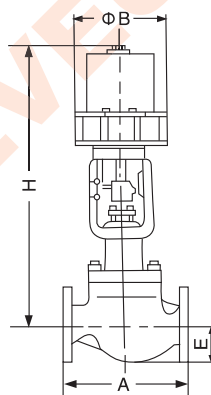

ZVA6 actuator

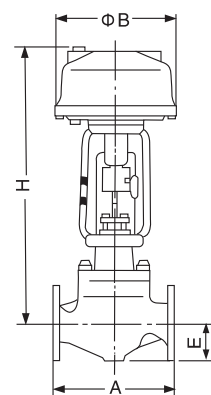

ZVP actuator

## Dimensions

mm

DN	A						
	JIS63K	ANSI 900		ANSI 1500		ANSI 2500	
	RF	RF ( SW, BW )	RJ	RF ( SW, BW )	RJ	RF ( SW, BW )	RJ
40	323	333	333	333	333	358	361
50	354	375	378	375	378	400	403
80	431	440	443	460	463	498	504
100	496	510	513	530	533	575	585
150	699	715	718	770	776	820	833
200	895	915	918	972	982	1020	1036



# LPH23

## High-pressure Cage Guided Control Valve



mm

DN	Actuator	H						E			C	B
		ANSI 900 JIS 63K		ANSI 1500		ANSI 2500		ANSI 900	ANSI 1500	ANSI 2500		
		Plain bonnet	Extension bonnet	Plain bonnet	Extension bonnet	Plain bonnet	Extension bonnet					
40	ZHA3D, R	735	875	735	875	780	925	100	105	120	363	350
	ZHA4D, R	890	1030	890	1030	935	1080				520	470
50	ZHA3D, R	765	925	765	925	800	960	110	120	130	363	350
	ZHA4D, R	925	1085	925	1085	960	1120				520	470
80	ZHA3D, R	800	980	800	980	835	1005	140	150	165	363	350
	ZHA4D, R	960	1140	960	1140	995	1165				520	470
100	ZHA3D, R	835	1015	835	1015	880	1050	160	170	195	363	350
	ZHA4D, R	995	1175	995	1175	1040	1210				520	470
	ZVA5D	1380	1560	1380	1560	1425	1595				-	620
	ZVA5R	1490	1670	1490	1670	1535	1705				-	620
	ZVA6R	1229	1409	1229	1409	1274	1444				-	445
150	ZHA3D, R	895	1075	895	1075	935	1110	210	225	260	363	360
	ZHA4D, R	1055	1235	1055	1235	1095	1270				520	470
	ZVA5D	1440	1620	1440	1620	1480	1655				-	620
	ZVA5R	1550	1730	1550	1730	1590	1765				-	620
	ZVA6R	1300	1480	1300	1480	1340	1515				-	445
	ZVP5	1080	1260	1080	1260	1120	1295				-	345
200	ZHA4D, R	1155	1395	1155	1395	1185	1370	280	290	330	520	470
	ZVA5D	1545	1785	1545	1785	1575	1760				-	620
	ZVA5R	1655	1895	1655	1895	1685	1870				-	620
	ZVP6	1395	1635	1395	1635	1425	1610				-	445

"H" dimensions are applicable when a hand wheel is not provided. When top-mounted hand wheel actuators or side-mounted hand wheel are used, add the hand wheel dimensions.

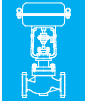

# LPH23

## High-pressure Cage Guided Control Valve



### Weight

kg

DN	Actuator	Flange						Weld					
		ANSI900 JIS63K		ANSI 1500		ANSI 2500		ANSI900 JIS63K		ANSI 1500		ANSI 2500	
		Plain bonnet	Extension bonnet	Plain bonnet	Extension bonnet	Plain bonnet	Extension bonnet	Plain bonnet	Extension bonnet	Plain bonnet	Extension bonnet	Plain bonnet	Extension bonnet
40	ZHA3D, R	60(55)	65(60)	65	70	90	95	50	55	55	60	75	80
	ZHA4D, R	90(85)	95(90)	95	100	125	130	80	85	85	90	105	110
50	ZHA3D, R	70(65)	80(75)	75	85	110	120	55	65	60	70	85	95
	ZHA4D, R	100(95)	110(105)	105	115	140	150	85	95	90	100	115	125
80	ZHA3D, R	105(100)	115(110)	140	160	225	245	85	95	110	130	170	190
	ZHA4D, R	135(130)	145(140)	170	190	255	275	115	125	140	160	200	220
100	ZHA3D, R	135(125)	160(150)	195	225	315	345	105	130	155	185	230	260
	ZHA4D, R	165(155)	190(180)	225	255	345	375	135	160	185	215	260	290
	ZVA5D	265(255)	290(280)	325	355	445	475	235	260	285	315	360	390
	ZVA5R	290(280)	315(305)	350	380	470	500	260	285	310	340	385	415
	ZVA6R	305(295)	330(320)	365	395	485	515	275	300	325	355	400	430
150	ZHA3D, R	345(330)	380(365)	525	570	875	915	285	320	435	480	660	700
	ZHA4D, R	395(360)	410(395)	555	600	905	945	315	350	465	510	690	730
	ZVA5D	475(460)	510(495)	655	700	1005	1045	415	450	565	610	790	830
	ZVA5R	500(485)	535(520)	680	725	1030	1070	440	475	590	635	815	855
	ZVA6R	515(500)	550(535)	695	740	1045	1085	455	490	605	650	830	870
	ZVP5	390(375)	425(410)	570	615	920	960	330	365	480	525	705	745
200	ZH4D, R	633(598)	678(643)	1065	1115	1500	1545	535	580	910	958	1193	1240
	ZVA5D	753(700)	780(745)	1165	1215	1600	1645	635	680	1010	1060	1295	1340
	ZVA5R	760(725)	805(770)	1190	1240	1625	1670	660	705	1035	1085	1320	1365
	ZVP5	725(690)	770(735)	1155	1025	1590	1635	625	670	1000	1050	1285	1330

The numbers in brackets are the weight of the nominal pressure JIS63K valve.

